

## PING))) Bracket Kit (#570-28015)

The PING))) Bracket Kit includes a standard servo and all mounting hardware required to attach the PING))) ultrasonic sensor to the front of Parallax's Small Chassis based robots:

- BASIC Stamp Boe-Bot Robot (#28832)
- Propeller ActivityBot, ActivityBot 360° (#32500, #32600)
- Shield-Bot (#32335, #130-35000)

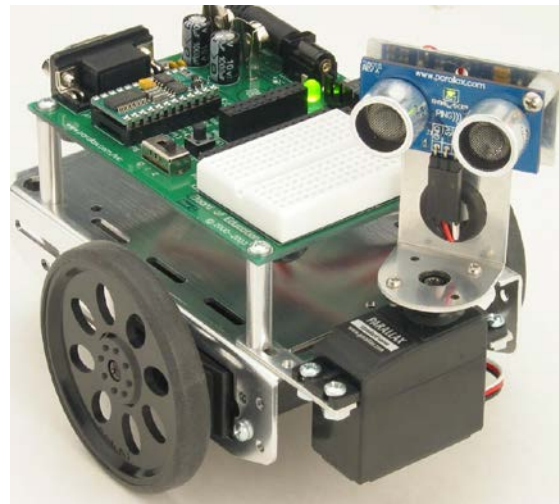

### Features

- Parallax Standard Servo provides 180 degrees of ultrasonic scanning ability
- Clean and sturdy connection provides reliable use on mobile robots
- Example projects available online at [learn.parallax.com](http://learn.parallax.com)

### Bill of Materials

Part#	Qty	Description
700-00003	5	Nut,#4-40,Zinc
700-00036	2	Nut, #4-40, Nylon
700-00015	3	Spacer,#4x1/16",NY
700-00025	1	Grommet,13/32"Dia,Rubber
700-00028	5	Screw,#4-40x1/4",PH,Zinc
700-00062	2	Screw,#2-56x1/4",PH,Zinc
710-00050	2	Screw,#4-40x1/2",PH,NY
711-00001	2	Nut, 2-56
713-00005	2	Spacer,#4x1/4",NY
720-00012	2	Universal Straight bracket
720-28015	1	Ping Aluminum Mounting Bracket
800-00120	1	3-wire ext.,22AWG,F/F,12"
900-00005	1	Parallax Servo-S05/STD/FP

### Tools Required

- A 3/32" drill bit or an X-Acto® knife
- A #2 Philips screwdriver (such as the Parallax screwdriver included in the Boe-Bot Robot Kit)
- Small Robot Chassis-based Parallax robot
- Or, any custom-made robot chassis that has a flat mounting spot on the front.
- Fresh batteries for your robot.

### Assembly Instructions

#### Step 1

The mounting holes on the PING))) mounting bracket accommodate both Futaba and Hitec servo sizes and locations. Identify the proper holes for your servo.

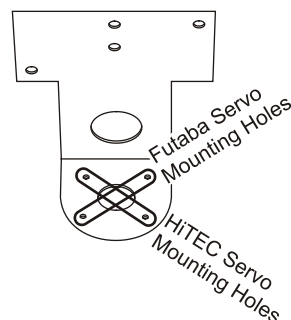

### Step 2

Enlarge two holes on the Standard Servo horn with a 3/32" (2.0 mm) drill bit or the tip of an X-Acto knife. Use caution in this step since the servo horn plastic is quite brittle and can crack if it is enlarged with a screw.

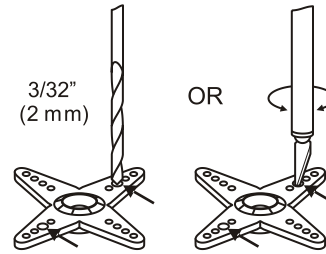

### Step 3

Attach the PING))) Mounting Bracket to the servo horn using (2) 2/56 1/4" long screws and (2) 2/56 nuts.

Put the rubber grommet in the bracket's larger hole.

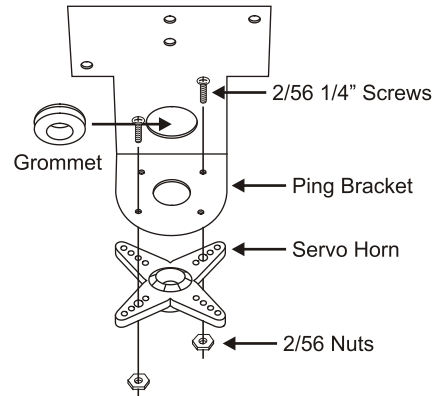

### Step 4

As viewed from the top, attach the PING))) Ultrasonic Distance Sensor to the PING))) Mounting Bracket using (2) Nylon 4/40 1/2" long screws, (2) Nylon Spacers and (2) Nylon #4/40 Nuts.

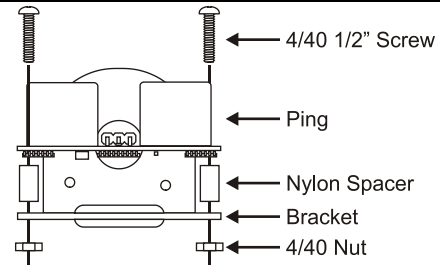

### Step 5

Disconnect power from your robot's development board. Then, remove the board and front right standoff from the small robot chassis.

Attach one straight bracket between the chassis and the front right standoff.

Attach the other straight bracket to the left-most slot in the top front of the chassis, using a 4/40 1/4" screw and nut.

Place a Nylon washer on top of the other three standoffs, and replace the development board on the chassis. The washers let the board remain level with the addition of the straight bracket under the fourth standoff.

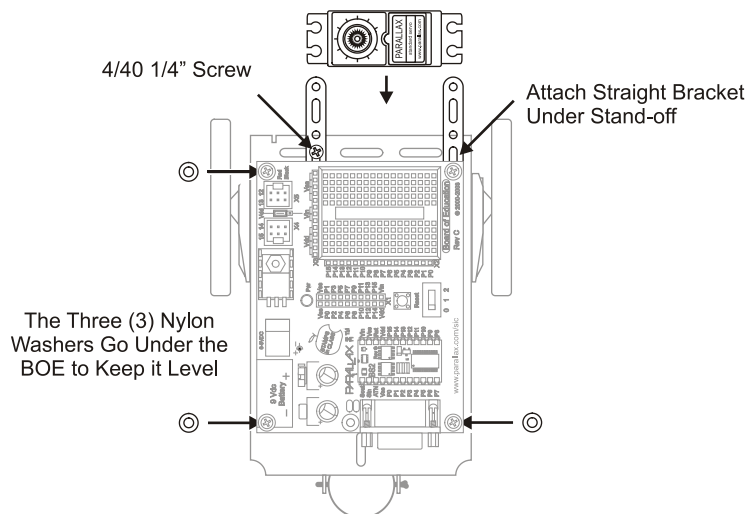

### Step 6

Rest the servo mounting tabs on top of the straight brackets, and attach using (4) 4/40 screws and (4) 4/40 nuts.

**Important: Before using the servo screw, adjust the Ping))) bracket to rotate 90° left and right.**

Replace the servo's shaft screw once the Ping))) Mounting Bracket is installed.

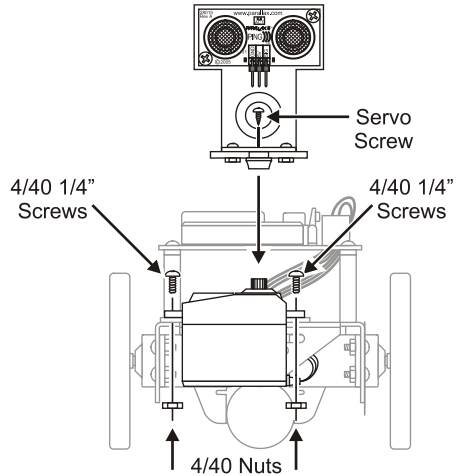

### Step 7

Connect the servo extension cable to the PING))) Sensor: Black to GND, Red to 5V, and White to SIG.

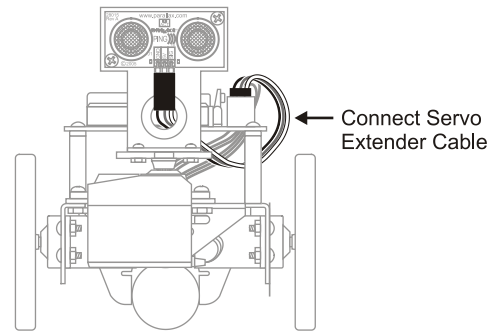

### Step 8

Search "570-28015" at [www.parallax.com](http://www.parallax.com) to find example code or links to projects.

If you are using a development board with 3-pin servo ports, set the Servo Port Jumper to VDD for the port you choose, then plug in the Standard Servo cable and the Ping))) Sensor cable. Be sure to match Black to GND, Red to 5V, and White to SIG.

NOTE: If your board has just one jumper, keep in mind this sets the servo voltage to 5 VDC for the robot's drive servos. This is adequate for the Parallax Continuous Rotation Servos included with the Boe-Bot and Robotics Shield Kit for Arduino. It is not sufficient for the High Speed Continuous Rotation Servos included with the ActivityBot Robot Kit, so use the 3<sup>rd</sup> set of ports on the Activity Board.

**CAUTION: SET SERVO PORT JUMPER TO 5V BEFORE CONNECTING PING))) SENSOR AND SERVO. DO NOT CONNECT THE PING))) SENSOR TO MORE THAN 5 VDC OR YOU WILL DAMAGE IT. USE THE IMAGES BELOW FOR REFERENCE.**

TOP-BOTTOM, LEFT-RIGHT:  
ACTIVITYBOT, SHIELD-BOT, BOE-BOT.

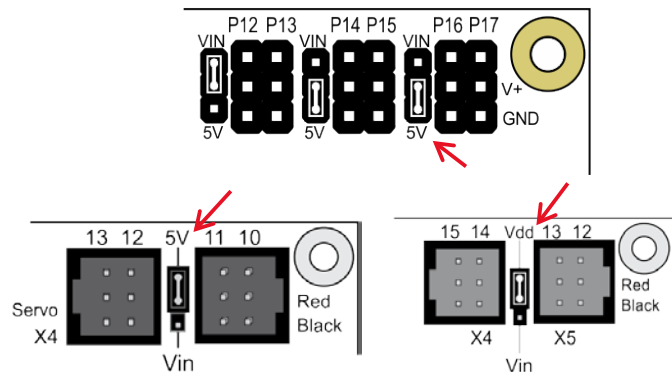

## Breadboard Connection

A breadboard connection will be necessary if:

- You are using a development board without a 3-pin Signal-5V-Ground connector.
- Your board has a servo port with a 3-pin Signal-5V-Ground connector, and a Vin/5V power jumper, but moving the jumper to Vin would negatively affect servos you wish to keep connected to Vin.

The PING))) Sensor requires a 5 VDC power supply. To make the connections directly from the breadboard:

1. Connect the servo extension cable to the PING))) sensor: Black to GND, Red to 5V, and White to SIG.
2. Place a 3-pin male/male header in the other end of the cable, and plug it into the breadboard. Be sure to position the cable where it won't interfere with the sensor when the bracket rotates.
3. Using jumper wires, connect the Black lead to Vss (Ground), the Red lead to 5V, and the White lead to an I/O pin. NOTE: if you are connecting the PING))) Sensor's SIG line directly to a 3.3 V Propeller P8X32A microcontroller I/O pin, use a 2.2 k-ohm resistor in series between the two.

Example breadboard connection to the BASIC Stamp HomeWork Board is shown below. Your development board may have power and ground connections in different locations, with different markings. The voltage value at Vdd and Vin may vary depending on which development board and power supply you are using. Refer to your board's documentation!

### BASIC STAMP HOMEWORK BOARD CONNECTION

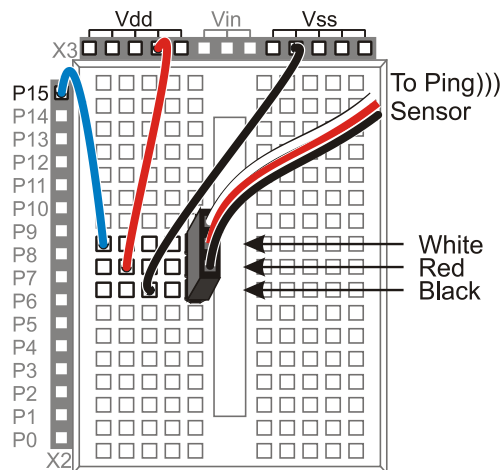

## Product Change Notice

Kits manufactured after October 2013 include two Nylon screws and two Nylon nuts. Kits manufactured after April 2014 may not include this printed product guide, which remains available online.

## Revision History

**Revision 2.3:** Added compatibility for the ActivityBot 360° Robot (#32600). Added images for the ActivityBot and Shield-Bot servo headers to Step 8 for visual reference when setting port jumpers to 5V.

**Revision 2.2:** Corrected Bill of Materials. Improved Step 4 to clarify use of Nylon parts. Improved Step 8 instructions for clarification. Expanded Breadboard Connection section.

**Revision 2.1:** Product change notice added. Assembly instructions updated to support all Parallax robots that use the aluminum Small Robot Chassis. Removed reference to discontinued Hitachi HM55B Compass Module.